

Missionary Diocese of Tasmania

Parish Mission Support Networks

In accordance with his rights and responsibilities as set out in the Diocesan Mission Support Team Ordinance 2000 and following a period of consultation, the Bishop wishes to advise the diocese of alterations to the structure of the Diocesan Mission Support Team.

The number of Parish Mission Support Networks in the diocese will be reduced from seven to four. **Non-parish Anglican organisations, projects and ministries will be supported through the office of the Bishop of Tasmania and the Missioner Bishops.**

Each network will have the support of three diocesan officers; a Mission Support Officer (MSO), a Network Chaplain (NC) and a Children's and Youth Ministry Development Officer (CYM). The position descriptions for each of these roles are attached.

The MSO positions will be funded by the Diocesan budget, the NC positions by Anglican Health and Welfare and the CYM positions by the Ministry Council.

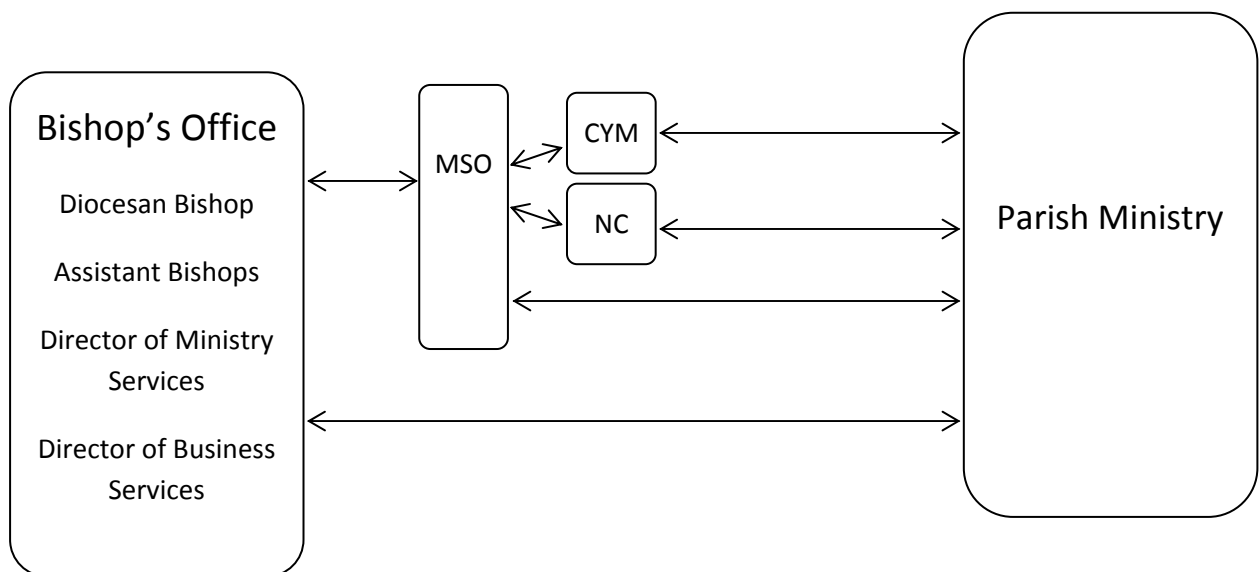

NW Network

Circular Head

Wynyard

West Coast

Burnie

Ulverstone

Penguin

Devonport

Latrobe

King Island

Sheffield

Northern Network

Furneaux

Riverlinks

L'ton Sth

St John's

Holy Trinity

L'ton North

Dorset

St Leonards

Break O' Day

West Tamar

Deloraine

Quamby

Longford

Cressy

Evandale/Nile

Nth Midlands

City Sth NetworkSt James/St
Andrews

St Johns

Moonah

Glenorchy

Claremont

Battery Point

Wellspring

All Saints

Sandy
Bay/Taroona

Kingston

Franklin/Esperance

Channel/Cygnets

Bruny Island

Cathedral

Sth East Network

Sandford

Howrah

Bellerive

Lindisfarne

T/R/Sorell

Buckland

Swansea

Sth Midlands

Brighton

Hamilton

New Norfolk

Bridgewater

The Anglican Church of Australia
Missionary Diocese of Tasmania
Position Description

Mission Support Officers

The Bishop delegates responsibilities in three principal areas to the Mission Support Officers.

1. Supporting the clergy and lay leaders within their network.
 - 1.1 ensuring access to appropriate personal pastoral support for clergy.
 - 1.2 overseeing the local response to any critical incident.
 - 1.3 establishing and maintaining a system of collegial support amongst the clergy of the network.
 - 1.4 facilitating the exchange of ministry resources and ideas within the network.

2. Facilitating the networks engagement with the Bishop's priorities.
 - 2.1 ensuring that clear lines of communication are established between the Bishop and parishes.
 - 2.2 ensuring that parish level and network wide discussion, response and engagement occurs.

3. Supporting the work of diocesan officers in the provision of specialist support for parishes and ministry units.
 - 3.1 guiding parishes through ministry transitions.
 - 3.2 assisting in establishing specialist support processes in areas such as mission action planning, conflict resolution, change management.
 - 3.3 supporting the work of the Registrar and Director of Ministry as required.

These responsibilities will be met by delivering and ensuring appropriate response to the following activities.

- a) Contact every stipendiary clergy within the network by phone or email at least monthly.
- b) Contact the Network Chaplain and Children's and Youth Ministry Coordinator to ensure adequate coordination of their ministries.
- c) Provide a first line of response to Ministry Issues that arise.
- d) Convene quarterly meetings of the clergy of the network ensuring that each of the Bishop, Director of Ministry and Registrar attend annually.
- e) Convene an annual mission conversations/workshops to include the clergy and lay leaders of the network, Bishop and Director of Ministry.
- f) Participate in six full day meetings with the Bishop and Director of Ministry, and other Mission Support Officers for the purpose of mutual support, accountability, strategic planning and professional development.
- g) Mission Support Officer act with the authority of the Bishop and are accountable to him. Appointments will be reviewed annually.

The Anglican Church of Australia
Missionary Diocese of Tasmania
Position Description

Children's and Youth Ministry Development Officers (CYMs)

1. The primary responsibility of CYMs will be to model the development of children's and youth ministry within their own parish.
2. CYMs will work with the local Mission Support Officer (MSO) to develop an annual network development plan.
3. CYMs are responsible to the Director of Ministry through the local Mission Support Officer and report in writing quarterly.
4. The Ministry Council will partner the home parish by funding twelve hours a week and an additional twelve days per year to enable to delivery of the following responsibilities,
 - a) to establish regular contact with all children's and youth ministries within their network . Focussing on creating links between the workers and wider networks. This may necessitate visiting ministry teams at least annually. (we would not expect the worker to be out of their parish for more than one weekend a month)
 - b) to coordinate local training and resource distribution. The CYMs will coordinate three training days or equivalent for the youth and children's ministries in their network. CYMs will also attend Fruitful and Ministry Conference. They will encourage leaders in their network to attend Fruitful Conference.
 - c) to coordinate the ministry traineeship scheme in their network.
 - d) to meet with each trainee at least quarterly whether in a group or individually and organise for all the trainees to meet as a network group twice a year.
 - e) to work with the network Mission Support Officer to guide and advise parishes seeking to develop children's and youth ministries by helping them identify and implement an appropriate local strategy. (Hawkins 20 year plan)
 - f) to assist in the development of a network camping program by coordinating the delivery of one camp each year.
 - g) to promote children's and youth ministry through regular contributions to Tasanglican, www.anglicantas.org.au and Diocesan gatherings or events.
 - h) to participate annually in a three days training and professional development program.
 - i) to attend the annual clergy conference.
5. CYMs will serve as members of the Children's and Youth Ministry Panel of Reference.

The Anglican Church of Australia
Missionary Diocese of Tasmania
Position Description

Network Chaplains

The role of Network Chaplains has been created by the Bishop to add to his capacity to provide intentional pastoral care to the clergy team. The hope is to combine the capacity to respond to critical need with planned, strategic support which maximizes the wisdom of the clergy who participate.

In order to ensure realistic work loads, the goal of a Network Chaplain is principally to facilitate effective pastoral care for the stipendiary clergy and employed licensed lay workers within each mission network. All others listed as active clergy in the diocesan directory should look to their rector for care but may also seek the support of a Network Chaplain. Rectors should assume responsibility for the care of clergy with authority to officiate or fully retired clergy who are members of their parish. Enablers have primary responsibility for the care of members of Local Ministry Support teams.

The Network Chaplain will :

1. Offer encouragement and support through regular contact by phone and email emphasising self-care
2. Facilitate appropriate care for distressed clergy at times of need
 - a) Meeting with individuals in times of need
 - b) Resourcing parish leadership in responding to clergy needs
 - c) Making appropriate connections. e.g. Mission Support Officer, Bishop, Diocese, colleagues
3. Encourage 'peer support' as an intentional part of all clergy networks.
 - a) Encouraging pairs or triads to meet regularly for worship, sharing of life-issues and prayer.
4. Encourage participation in "mentoring" relationships.
 - a) Identifying individuals willing and able to serve in these capacities.

Network Chaplains act with the authority of the Bishop and are accountable to him. Appointments will be reviewed annually.